

CC34B UTILITY COMPACTOR | 4T

PRODUCT SPECIFICATIONS

CAT

Type	Combination Roller
Specifications	
Engine Model	CAT C2.2 Engine
Rated Power	36.4 kW (48.8 hp)
Maximum Weight	3,913 kg
Static Linear Load	14.2 kg/cm (pli)
Amplitude	0.50 mm
Frequency	55 Hz
Centrifugal Force - High	33.9 kN
- Low	25.9 kN
Speed Range (km/ h)	0-13.5 km/h
Water Tank	241 L
Fuel Burn	
Low	2.0 - 3.2 Litres per hour
Medium	3.2 - 4.5 Litres per hour
High	4.5 - 6.0 Litres per hour

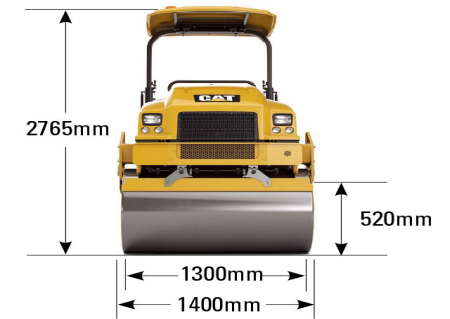
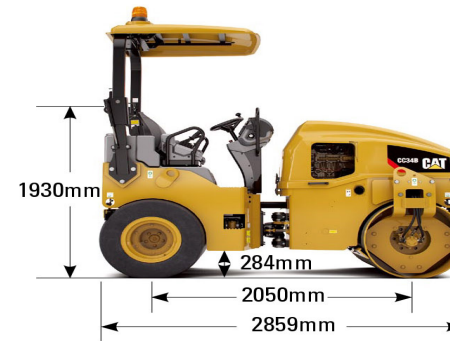

Drum offset 50mm
Drum shell thickness 16mm
Drum diameter 800mm