

CB7 TANDEM VIBRATORY ROLLER | 9T

PRODUCT SPECIFICATIONS

CAT

Type	Double Drum
Specifications	
Engine Model	CAT C2.4B
Gross Power Tier 4 Interim - Stage IIIB	75 kW (100 hp)
Operating Weight	8,190 kg (max 8,940 kg)
Static Linear Load	26.9 kg/cm
Amplitude - Solid drum VT1	0.25mm (low) - 0.64mm (high)
Frequency	53.3 Hz
Centrifugal Force - High	76.9 kN
- Low	30.2 kN
Speed Range (km/ h)	0-12 km/h
Water Tank (l)	742 L
Fuel Burn	
Low	6.8 Litres per hour
Medium	8.3 Litres per hour
High	10.2 Litres per hour

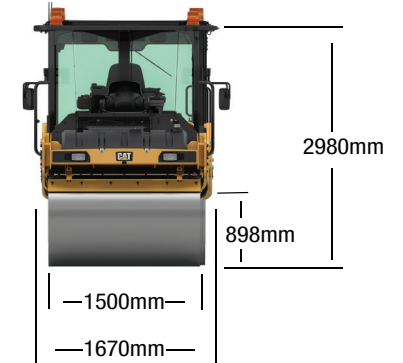
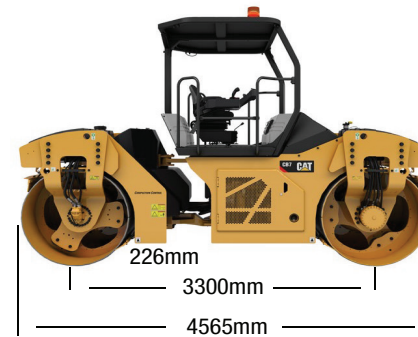

Drum Offset	170 mm
Drum Shell Thickness	16 mm
Drum Diameter	1108 mm