

CC900 VIBRATORY ROLLER | 1.6T

PRODUCT SPECIFICATIONS

DYNAPAC

Type	Double Drum
Masses	
Maximum Operating Mass	1,665 kg
Traction	
Speed Range (km/ h)	0-9 km/h
Vertical Oscillation	±13°
Theor. Gradeability	40 %
Compaction	
Centrifugal Force	17 kN
Static Linear Load - Rear	8.3 kg/cm / 9.4 kg/cm
Vibration Frequency	70 Hz
Water Tank (l)	190L
Engine	
Manufacturer	Kubota
Model	D1105-E4B T4f
Type	Water cooled Diesel
Rated Power - SAE J1995	18 kW (24 hp) @ 2,800 rpm
Fuel Tank Capacity	23 L
Fuel Burn	
Medium	2.8 Litres per hour
High	5.6 Litres per hour

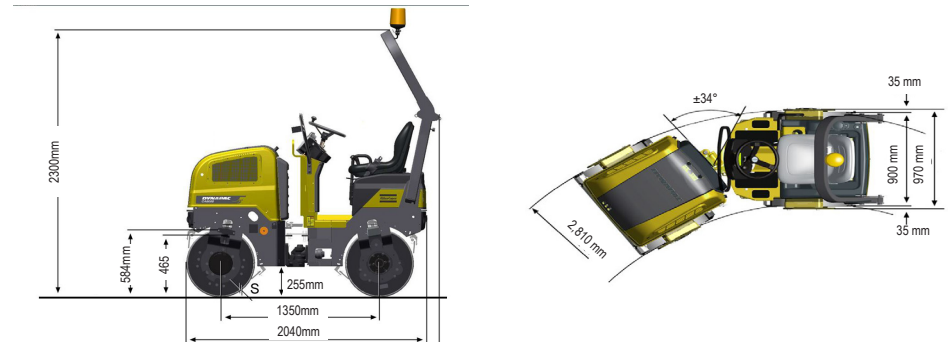

DISCLAIMER: This Product Specification Sheet was produced 01/2020. Every effort has been made to ensure that the content is accurate, however the contents are subject to change. Information contained in this Specification Sheet is: for general information only and does not purport to be comprehensive, current only at the time it is placed in this document compiled from manufacturer and industry sources; and not intended to provide nor make any recommendation upon which you should rely for any purpose whatsoever. Ezyquip Hire makes no warranty express or implied, including without limitation any warranty of merchantability or fitness for any particular purpose. Ezyquip Hire shall not be liable for any special, incidental, or consequential damages or loss of profits resulting from use of or misuse of the general information provided in this document.