

A140 HYDRAULIC DRILL RIG | 39T

PRODUCT SPECIFICATIONS

IMT

Specification	Units
Engine Type	Cummins QSB 6,7 T3/T4
Installed Torque	140 kNm
Maximum Working Speed	25 RPM
Maximum Discharge Speed	112 RPM
Drill Specifications	
Main Winch - Pull Force	145 kN
Main Winch - Speed	90 m/min / 295 ft/min
Main Winch - Cable Diameter	22 mm
Auxiliary Winch - Pull Force	60 kN
Auxiliary Winch - Speed	40 m/min / 131 ft/min
Auxiliary Winch - Cable Diameter	15 mm
Kelly Crowd - Push	110 kN
Kelly Crowd - Pull	175 kN
Stroke (mm)	3,600 mm
Undercarriage - Length	4,690 mm / 185"
Undercarriage - Widening Range	2550 - 3800 mm / 100 - 149'3"
Undercarriage - Shoe	600 mm / 23'6"
Mast Ranking - Forward	5°
Mast Side Ranking	±5°
Mast Ranking - Backwards	15°
Hole Size	450mm - 2,100 mm
Drill Depth	19m in depth - low head room conversion 40m in depth - standard Kelly Mast
Low Head Room	Max 7.5m / 9m
Fuel Burn	17 L/ph

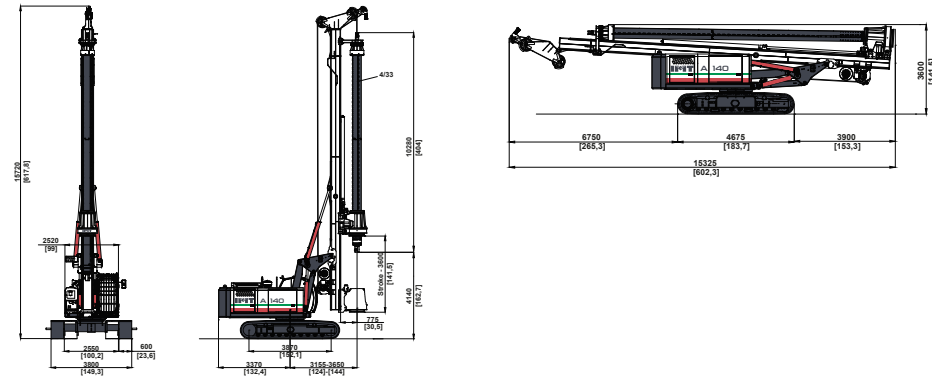

DISCLAIMER: This Product Specification Sheet was produced 01/2020. Every effort has been made to ensure that the content is accurate, however the contents are subject to change. Information contained in this Specification Sheet is for general information only and does not purport to be comprehensive, current only at the time it is placed in this document compiled from manufacturer and industry sources; and not intended to provide nor make any recommendation upon which you should rely for any purpose whatsoever. Ezyquip Hire makes no warranty express or implied, including without limitation any warranty of merchantability or fitness for any particular purpose. Ezyquip Hire shall not be liable for any special, incidental, or consequential damages or loss of profits resulting from use of or misuse of the general information provided in this document.