

980K WHEEL LOADER | 31T

PRODUCT SPECIFICATIONS

CAT

Engine	
Model	CAT C13 ACERT
Max Gross Power (1600 rpm) - SAE J1995	303 kW / 406 hp
Max Net Power - ISO 9249	274 kW / 369 hp
Net Power - SAE J1349	274 kW / 369 hp
Net Power - 80/1269/EEC	274 kW / 369 hp
Peak Gross Torque (1,300 rpm) - SAE J1995	2,089 Nm / 1,541 ft-lb
Peak Net Torque (1,200 rpm) - SAE J1349	1,959 Nm / 1,445 ft-lb
Bore	130 mm
Stroke	157 mm
Displacement	12.5 L
Cat engine with ACERT Technology – meets Tier 4 Interim/Stage IIIB emission standards.	
Weights	
Operating	31,244 kg
Buckets	
Bucket Capacities	4.0 - 12.2 m ³
Operating Specifications	
General Purpose Bucket - Pin On Bolt-On Edges	
Capacity – Rated (§)	5.70 m ³
Capacity – Struck (§)	4.50 m ³
Width (§)	3,447 mm
Dump Clearance - At max lift and 45° discharge (§)	3,204 mm
Reach - At max lift and 45° discharge (§)	1,604 mm
Reach - At level lift arm and bucket level (§)	3,124 mm
Digging Depth (§)	103 mm
Overall Length	9,593 mm
Overall Height - With bucket at max lift	6,243 mm
Loader Clearance Circle Radius - With bucket in carry position	15,898 mm
Static Tipping Load - Straight (ISO)*	21,425 kg
Static Tipping Load - Straight (Rigid Tire)*	22,787 kg
Static Tipping Load - Articulated (ISO)*	18,883 kg
Static Tipping Load - Articulated (Rigid Tire)*	20,101 kg
Breakout Force ** (§)	224 kN
Operating Weight*	31,473 kg

Transmission	
Forward 1	6.8 km/h
Forward 2	12.1 km/h
Forward 3	21.5 km/h
Forward 4	37.8 km/h
Reverse 1	7.8 km/h
Reverse 2	13.9 km/h
Reverse 3	24.5 km/h
Reverse 4	42.8 km/h
Fuel Burn	
Low	13.8 - 19.2 Litres per hour
Medium	19.2 - 24.0 Litres per hour
High	24.0 - 29.7 Litres per hour

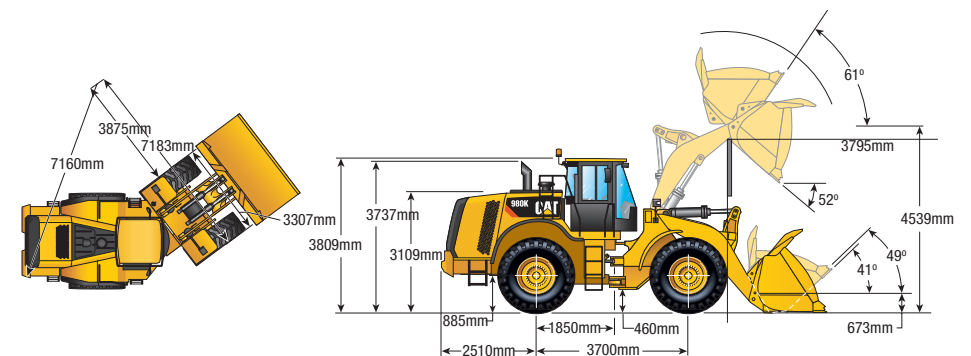

DISCLAIMER: This Product Specification Sheet was produced 01/2020. Every effort has been made to ensure that the content is accurate, however the contents are subject to change. Information contained in this Specification Sheet is: for general information only and does not purport to be comprehensive, current only at the time it is placed in this document compiled from manufacturer and industry sources; and not intended to provide nor make any recommendation upon which you should rely for any purpose whatsoever. Ezyquip Hire makes no warranty express or implied, including without limitation any warranty of merchantability or fitness for any particular purpose. Ezyquip Hire shall not be liable for any special, incidental, or consequential damages or loss of profits resulting from use of or misuse of the general information provided in this document.