

313FL HYDRAULIC EXCAVATOR | 13T

PRODUCT SPECIFICATIONS

CAT

Weights	
Operating Weight	13,400 kg
Engine	
Model	CAT C6.4 ACERT
Net power SAE J1349/ISO 9249	68 kW
Engine Power – ISO 14396	74 kW
Bore	105 mm
Stroke	127 mm
Displacement	4.4 L
Fuel Burn	
Low	3.4 - 6.7 Litres per hour
Medium	6.7 - 10.0 Litres per hour
High	10.0 - 13.3 Litres per hour

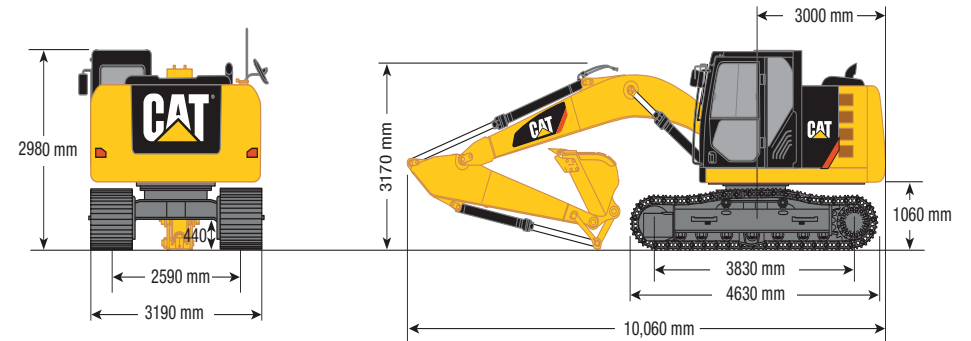

DISCLAIMER: This Product Specification Sheet was produced 01/2020. Every effort has been made to ensure that the content is accurate, however the contents are subject to change. Information contained in this Specification Sheet is: for general information only and does not purport to be comprehensive, current only at the time it is placed in this document compiled from manufacturer and industry sources; and not intended to provide nor make any recommendation upon which you should rely for any purpose whatsoever. Ezyquip Hire makes no warranty express or implied, including without limitation any warranty of merchantability or fitness for any particular purpose. Ezyquip Hire shall not be liable for any special, incidental, or consequential damages or loss of profits resulting from use of or misuse of the general information provided in this document.